

THIS DRAWING IS UNPUBLISHED. RELEASED FOR PUBLICATION 20  
 © COPYRIGHT 20 BY - ALL RIGHTS RESERVED.

LOC	DIST	REVISIONS					
HM	00	P	LTR	DESCRIPTION	DATE	DWN	APVD
		F		REV ECO-11-000935	14JAN2011	LH	RA
		G		REV ECO-11-010380	20MAY2011	LH	RA

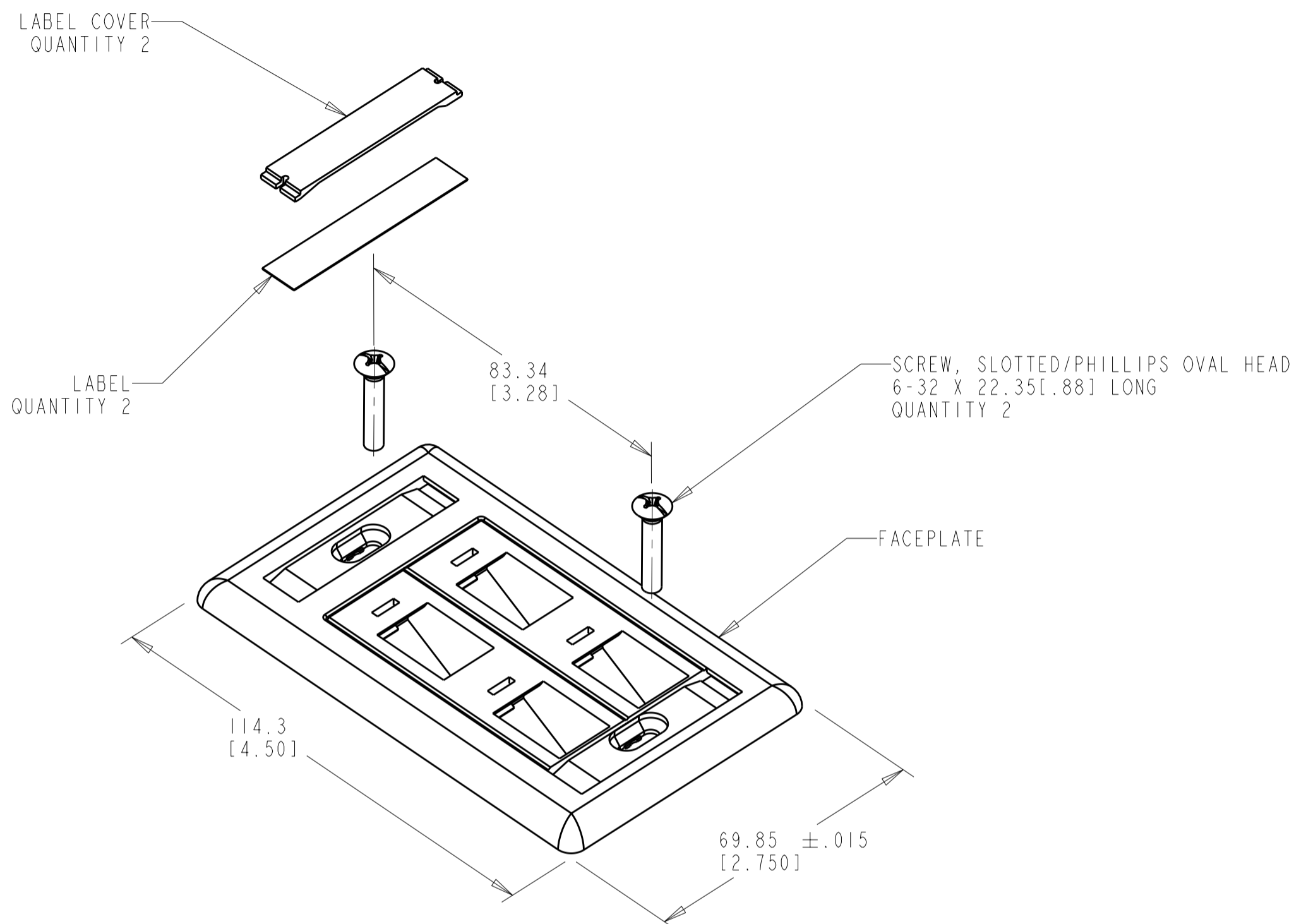

1. MATERIAL: FACEPLATE - POLYCARBONATE MOLDING COMPOUND. SEE TABLE FOR COLOR.  
 ICON - POLYCARBONATE MOLDING COMPOUND. SEE TABLE FOR COLOR.  
 LABEL COVER - POLYCARBONATE MOLDING COMPOUND, CLEAR.  
 LABEL - WHITE INDEX PAPER.  
 SCREW - ZINC PLATED CARBON STEEL.
2. THIS KIT SHIPPED NOT ASSEMBLED.

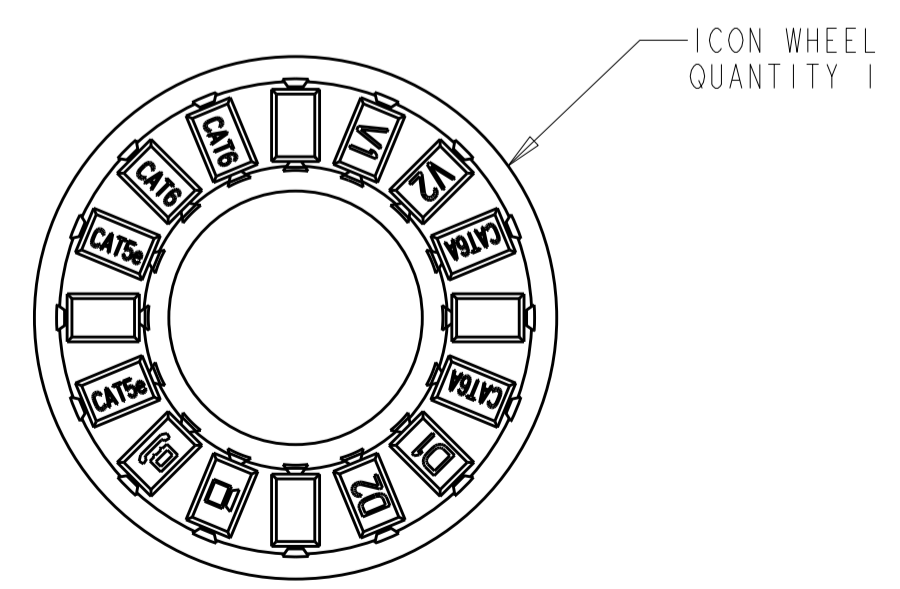

ALPINE WHITE	1-406185-3
ELECTRICAL IVORY	1-406185-1
NEMA GRAY	406185-4
WHITE	406185-3
BLACK	406185-2
LIGHT ALMOND	406185-1
COLOR	PART NO.

THIS DRAWING IS A CONTROLLED DOCUMENT.

DWN B. SIMPSON 10SEP96  
 CHK N. JONES 26SEP96  
 APVD P. PEPE 01OCT96

TE Connectivity

NAME: FACEPLATE KIT, 4 PORT 110 CONNECT

SIZE: A2 CAGE CODE: 00779 DRAWING NO: 406185 RESTRICTED TO: -

SCALE: 1:1 SHEET: 1 OF 1 REV: G

CUSTOMER DRAWING