

THIS DRAWING IS UNPUBLISHED. RELEASED FOR PUBLICATION .19  
 © COPYRIGHT 19 BY AMP INCORPORATED. ALL RIGHTS RESERVED.

LOC	DIST	REVISIONS			
P	LTR	DESCRIPTION	DATE	DWN	APVD
AA	27	0	RLSD; NPR C99-117	15JUL99	GG GB

D

C

B

A

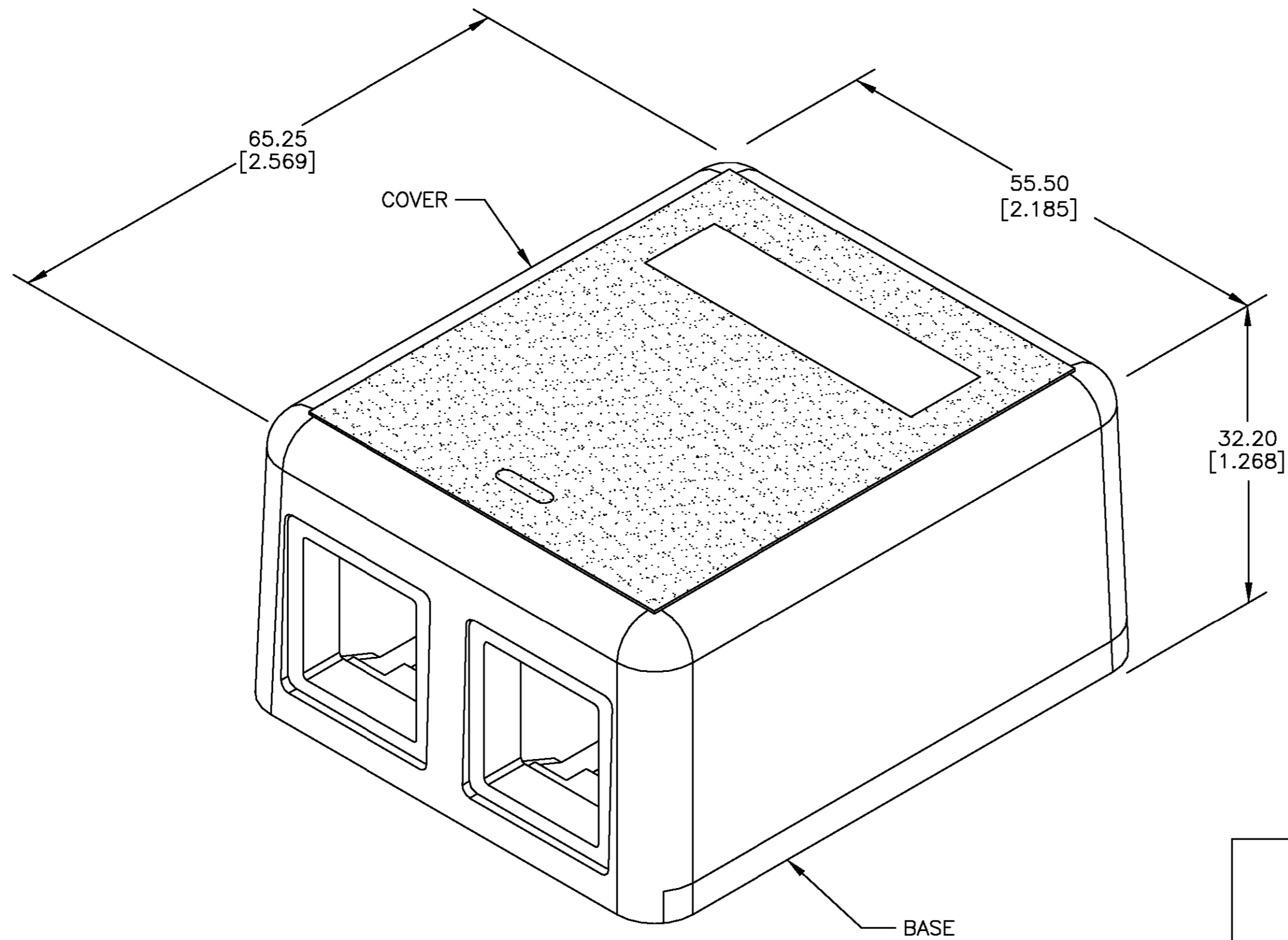

1. MATERIAL: BASE AND COVER - ABS MOLDING COMPOUND UL94V-0. SEE TABLE FOR COLOR. CABLE TIE - NYLON. SCREWS - ZINC PLATED CARBON STEEL.
2. PACKAGED 1 KIT PER POLYBAG.
3. ALL DIMENSIONS SHOWN ARE MAXIMUM.

D

C

B

A

1116698

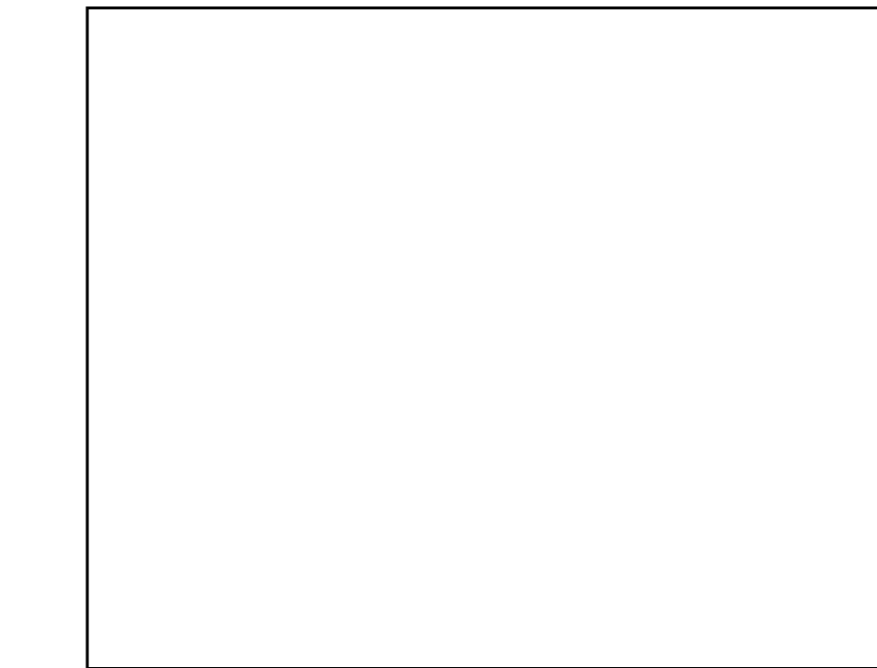
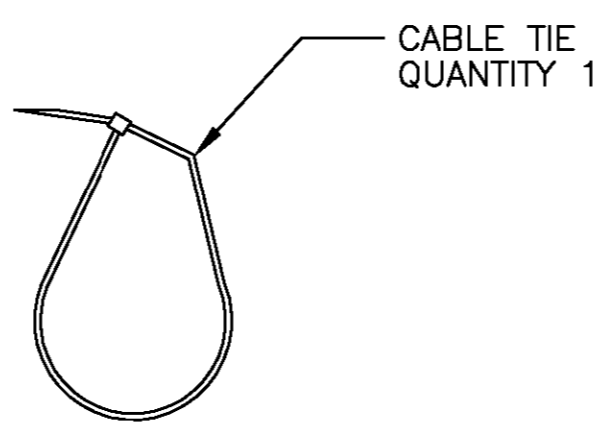
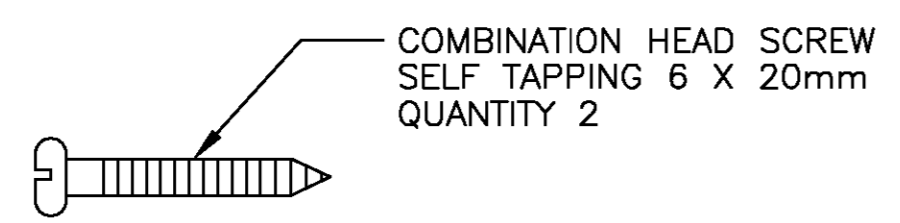

DOUBLE SIDED FOAM TAPE QUANTITY 1

COLOR	PART NUMBER
ELECTRIC IVORY	1-1116698-1
NEMA GRAY	1116698-4
WHITE	1116698-3
BLACK	1116698-2
LIGHT ALMOND	1116698-1

THIS DRAWING IS A CONTROLLED DOCUMENT.		DWN G. GARRETT 15JUL99	AMP Incorporated Harrisburg PA 17105-3608	
DIMENSIONS: mm [INCHES]		CHK G. BOWMAN 15JUL99	NAME G. BOWMAN	
TOLERANCES UNLESS OTHERWISE SPECIFIED:		APVD G. BOWMAN 15JUL99	PRODUCT SPEC	
0 PLC	± -	APPLICATION SPEC		
1 PLC	± -	WEIGHT		
2 PLC	± -	SIZE		
3 PLC	± -	CAGE CODE		
4 PLC	± -	DRAWING NO		
ANGLES	± -	RESTRICTED TO		
FINISH	-	A2 00779 C-1116698		
MATERIAL		CUSTOMER DRAWING		SCALE 2:1 SHEET 1 OF 1 REV 0