

THIS DRAWING IS UNPUBLISHED. RELEASED FOR PUBLICATION .19
 © COPYRIGHT 19 BY AMP INCORPORATED. ALL RIGHTS RESERVED.

LOC	DIST	REVISIONS			
P	LTR	DESCRIPTION	DATE	DWN	APVD
HM	00	B	ECO-14-007046	05AUG14	JM RA

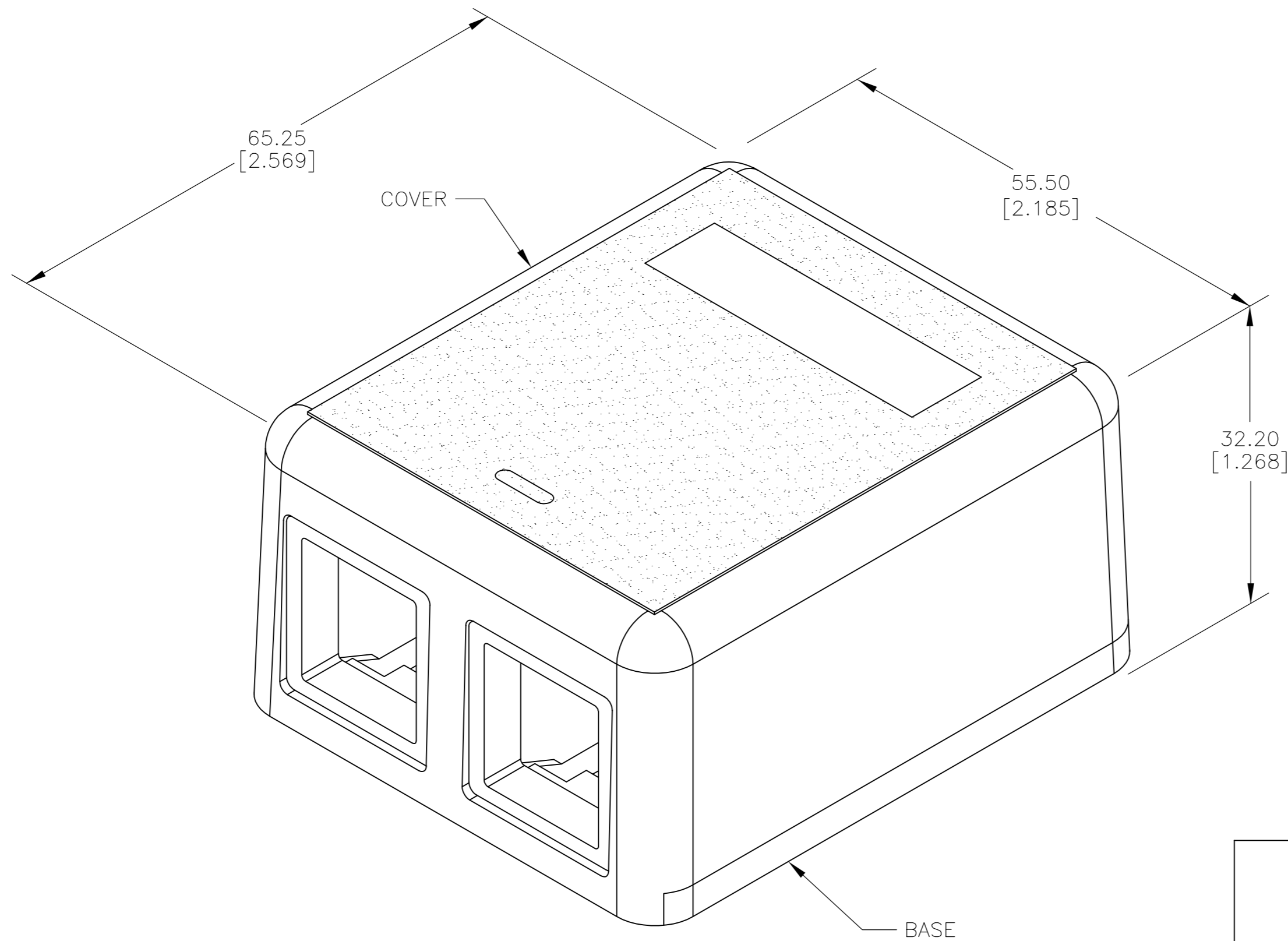

1 MATERIAL: BASE AND COVER - ABS MOLDING COMPOUND UL94V-0. SEE TABLE FOR COLOR. CABLE TIE - NYLON SCREWS - ZINC PLATED CARBON STEEL.

- 2. PACKAGED 1 KIT PER POLYBAG.
- 3. ALL DIMENSIONS SHOWN ARE MAXIMUM.

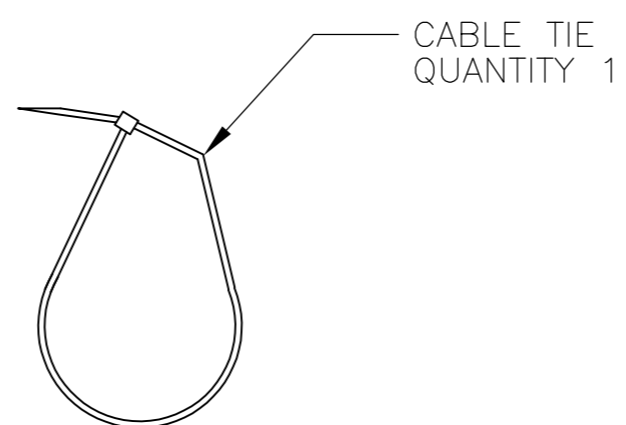

DOUBLE SIDED FOAM TAPE QUANTITY 1

ALPINE WHITE	1-1116698-3
ELECTRIC IVORY	1-1116698-1
NEMA GRAY	1116698-4
BLACK	1116698-2
LIGHT ALMOND	1116698-1
COLOR	PART NUMBER

THIS DRAWING IS A CONTROLLED DOCUMENT.

DWN	G. GARRETT	17AUG99
CHK	G. BOWMAN	15JUL99
APVD	G. BOWMAN	15JUL99

NAME: AMP Incorporated, Harrisburg PA 17105-3608

PRODUCT SPEC: KIT, DUAL PORT MODULAR JACK BOX

SIZE	CAGE CODE	DRAWING NO	RESTRICTED TO
A2	00779	C-1116698	-

CUSTOMER DRAWING SCALE: 2:1 SHEET 1 OF 1 REV B